

國立台灣清華大學 工程與系統科學系

先進冷卻散熱實驗室

(Advance Cooling Laboratory---ACL)

T.I.M.

Performance Test Report

Project Name:

P/N:

清華大學工程與系統科學系
Tsing Hua University
Dept. of Engineering and System Science
電子構裝散熱系統
實驗室
ESC Lab.



Notice: This document has released under a Non-Disclosure Agreement to:

CUSTOMER : SYM BANG

Model: Sample1~2

This Document has been released from:

Approved By: Professor Lin, Wei-Keng

Wei-Keng Lin

Tester: E, YA-LING

Test Date: 2017.05.16

	National Tsing-Hua University--Taiwan ESS Dept.	TIM Performance Test	Advance Cooling Laboratory---ACL	
Issued Date: 2017.06.13 Revised Date: 2017.06.13		Document Ref. No: SB-report-170613	Revision: 2.0	Pages: 1 / 19

1. Overview..... 2

1.1 Document History 2

1.2 Test Configuration..... 3

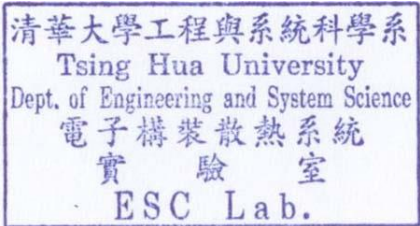

2. Thermal Properties Measurement Instrument For Thermal Interface

Material (T. I. M)..... 4

2.1 Test Theory..... 4

2.1.1 Test Theory for the T.I.M..... 4

2.2 Test Facility..... 9

2.2.1 Facility picture 9

2.2.2 K measurement for metal Test..... 11

2.2.3 K measurement for thermal grease..... 14

2.2.4 K measurement for thermal pad..... 16

2.3 Test Results..... 17

2.3.1 Thermal grease..... 17



	National Tsing-Hua University--Taiwan ESS Dept.	TIM Performance Test	Advance Cooling Laboratory---ACL	
Issued Date: 2017.06.13 Revised Date: 2017.06.13		Document Ref. No: SB-report-170613	Revision: 2.0	Pages: 2 / 19

1. Overview

1.1 Document History

Item	Revision	Description	Date	Originator
1	2.0	Test Sample1(G79-SiC-A)	2017/05/02	E,YA-LING
2	2.0	Test Sample2(G79-SiC-B)	2017/05/16	E,YA-LING

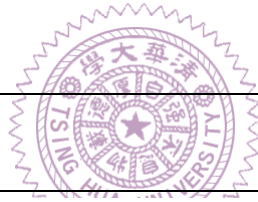

清華大學工程與系統科學系
Tsing Hua University
Dept. of Engineering and System Science
電子構裝散熱系統
實驗室
ESC Lab.

	National Tsing-Hua University--Taiwan ESS Dept.	TIM Performance Test	Advance Cooling Laboratory---ACL	
			Issued Date: 2017.06.13 Revised Date: 2017.06.13	Document Ref. No: SB-report-170613

1.2 Test Configuration

Item	Model	Supplier	K (W/m ² C)
1	Sample1_G79-SiC-A	NTHU ESS	3.0
2	Sample2_G79-SiC-B	NTHU ESS	3.2

P.S. : All the K data test from T.I.M. Instrument was based on ASTM-D5470, Due to the surface tension and viscosity effect, the higher K value doesn't represent a low thermal resistance. A thermal resistance test data need to take from thermal resistance test instrument.



	National Tsing-Hua University--Taiwan ESS Dept.	TIM Performance Test	Advance Cooling Laboratory---ACL	
			Issued Date: 2017.06.13 Revised Date: 2017.06.13	Document Ref. No: SB-report-170613

2. Thermal Properties Measurement Instrument For Thermal Interface Material (T. I. M)

2.1 Test Theory

2.1.1 Test Theory for the T.I.M.

(I) Thermal Analysis:

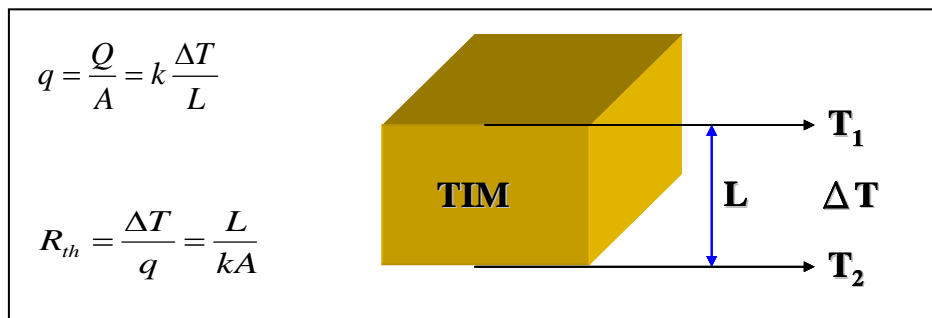

Fig. 1 Schematic diagram for T.I.M

k : thermal conductivity (W/m°C)

L : thickness of the T.I.M. (or test sample) (m)

ΔT=T₂-T₁ : temperature gradient (°C)

A : cross section area of the T.I.M. (m²)

Q: Total heat (W)

q: heat flux (W/m²)

R_{th}: thermal resistance of the T.I.M. (or test sample)

	National Tsing-Hua University--Taiwan ESS Dept.	TIM Performance Test		Advance Cooling Laboratory---ACL	
		Issued Date: 2017.06.13 Revised Date: 2017.06.13	Document Ref. No: SB-report-170613	Revision: 2.0	Pages: 5 / 19

(II) ASTM-D5470

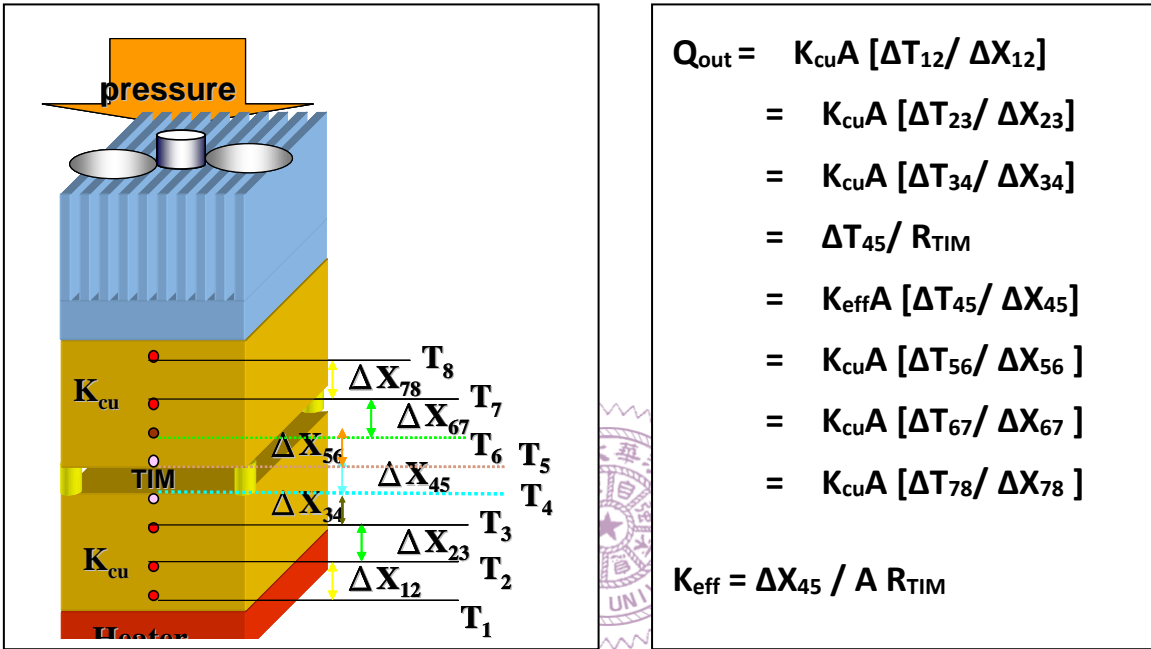



Fig. 2 Schematic diagram for T.I.M. test fixture based on ASTM-D5470

	National Tsing-Hua University--Taiwan ESS Dept.	TIM Performance Test		Advance Cooling Laboratory---ACL	
		Issued Date: 2017.06.13 Revised Date: 2017.06.13	Document Ref. No: SB-report-170613	Revision: 2.0	Pages: 6 / 19

(III) T.I.M. (Test sample) R_{th} calculation

$$R_{tot} = R_{int1} + R_{gr} + R_{int2} = R_{contact} + R_{gr}, \quad \frac{\partial R_{tot}}{\partial L} = \frac{\partial R_{contact}}{\partial L} + \frac{\partial R_{gr}}{\partial L},$$

$$\therefore \frac{\partial R_{contact}}{\partial L} = 0, \quad \therefore \frac{\partial R_{tot}}{\partial L} = \frac{\partial R_{gr}}{\partial L} R_{gr} = \frac{L}{k_{gr}A}, \quad \frac{\partial R_{gr}}{\partial L} = \frac{1}{k_{gr}A} = \frac{\partial R_{tot}}{\partial L},$$

$$\therefore k_{gr} = \frac{1}{A} \frac{1}{\left(\frac{\partial R_{tot}}{\partial L}\right)} = \frac{1}{A} \frac{1}{\left(\frac{\partial R_{gr}}{\partial L}\right)}$$

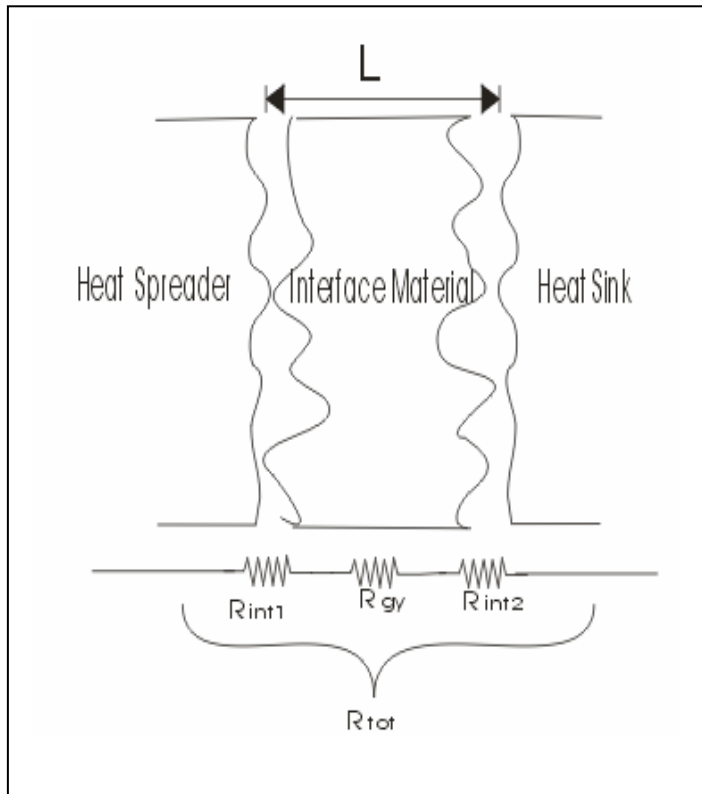



Fig.3 Schematic diagram for T.I.M. contact

	National Tsing-Hua University--Taiwan ESS Dept.	TIM Performance Test	Advance Cooling Laboratory---ACL	
			Issued Date: 2017.06.13 Revised Date: 2017.06.13	Document Ref. No: SB-report-170613

(IV) Schematic diagram of the T.I.M. test loop

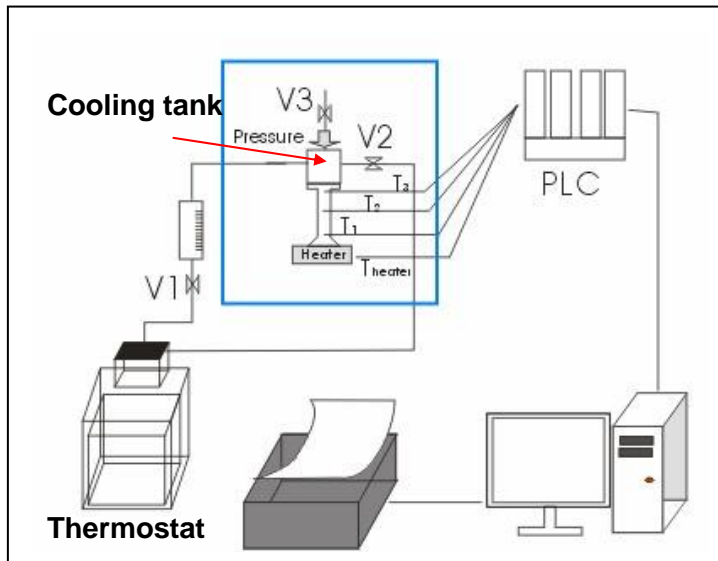

Fig. 4 Schematic diagram for T.I.M. test loop based on ASTM-D5470

(V) System Introduce:

1. Design concept of the system is based on ASTM, D5470
2. Using the fast handling ability of the PC, the massive test data may be taken in a short time and calculated by statistical principle, repeatability is extremely high..
3. This system provide on-line measurement and auto calculate the thermal resistance and K value of the Thermal Grease 、 Thermal Pad and other test metal sample. The system also provides all the characteristic figures.
4. Easy and simple operation. The coordinate is adjustable so that it may suitable for any kind value of the power or thermal resistance.
5. Test data can be saved in the hard disk with the RTF format, so that one may easy to e-mail to the customers.
6. Data report include (Rth Vs. Q), (Rth Vs. Pressure), (Rth Vs. Thickness) and other basic raw material data.
7. System is asked to heat up to 300W, all the temperatures, power load can be observed from panel and transit to the computer simultaneously.
8. Software program (Fig. 5) is developed by ACL lab. of the ESS Dept. of Tsing-Hua University, Taiwan. Update program is therefore for free.
9. System is expandable, K value of the Vapor Chamber is developing for the next generation.



	National Tsing-Hua University--Taiwan ESS Dept.	TIM Performance Test	Advance Cooling Laboratory---ACL	
Issued Date: 2017.06.13 Revised Date: 2017.06.13		Document Ref. No: SB-report-170613	Revision: 2.0	Pages: 8 / 19



Fig. 5. Software program for T.I.M./Pad/metal test

	National Tsing-Hua University--Taiwan ESS Dept.	TIM Performance Test	Advance Cooling Laboratory---ACL	
			Issued Date: 2017.06.13 Revised Date: 2017.06.13	Document Ref. No: SB-report-170613

2.2 Test Facility

2.2.1 Facility picture



Fig. 6 T.I.M. test fixture based on ASTM-D5470



Fig. 7 Power supply for T.I.M. test Instrument based on ASTM-D5470

	National Tsing-Hua University--Taiwan ESS Dept.	TIM Performance Test	Advance Cooling Laboratory---ACL	
Issued Date: 2017.06.13 Revised Date: 2017.06.13		Document Ref. No: SB-report-170613	Revision: 2.0	Pages: 10 / 19

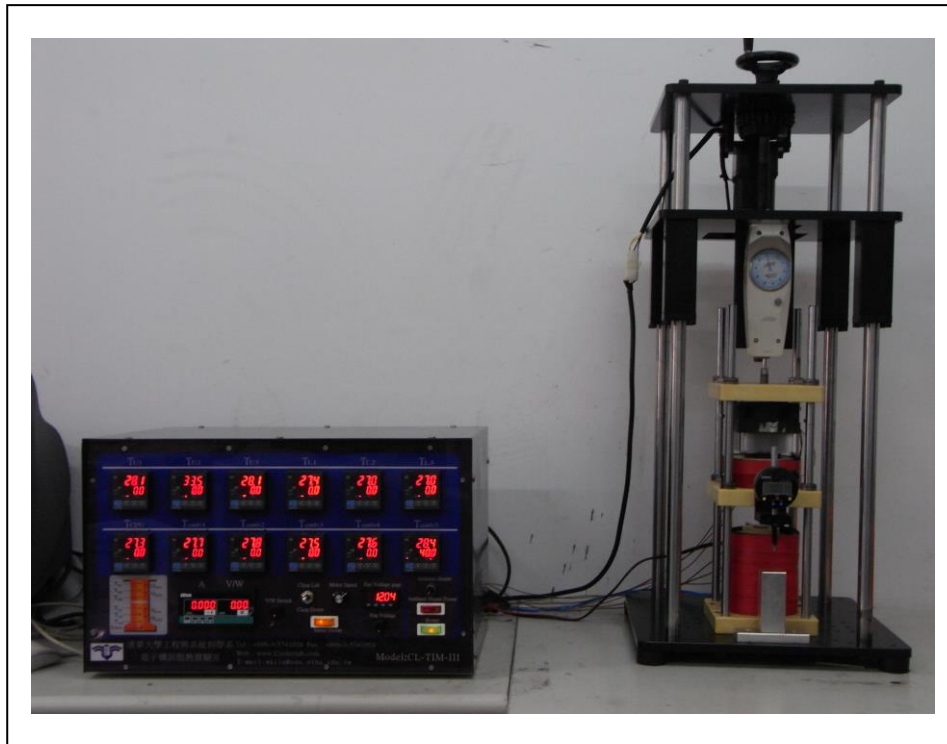



Fig. 8 T.I.M. test Instrument based on ASTM-D5470

	National Tsing-Hua University--Taiwan ESS Dept.	TIM Performance Test	Advance Cooling Laboratory---ACL	
Issued Date: 2017.06.13 Revised Date: 2017.06.13		Document Ref. No: SB-report-170613	Revision: 2.0	Pages: 11 / 19

2.2.2 K measurement for metal Test

A well insulated lower copper block and a well insulated upper copper block are inserted into the lower module and the upper module respectively (Fig. 9, 10). A stable heat flux is then generated from the bottom of the lower module and transit to the upper module (Fig.11) where heat is dissipated by a cooler (or thermostat) (Fig.12). Put the test metal sample between lower module and upper module and align very carefully, then Clamp these two pieces of modules tightly. The contact lower temperature and the contact upper temperature of the test metal sample are then predicted by the Fourier's cooling law, the unknown K value of the metal sample is then be calculated by Fourier's law again by the known data: thickness of the test metal sample · the upper contact temperature and the lower contact temperature (Fig. 13). Table 1. Sample test result for the thermal conductivity of the copper. Fig.14 K value for Cu with respect to different Q.





National Tsing-Hua
University--Taiwan
ESS Dept.

TIM
Performance Test

Advance Cooling
Laboratory---ACL

Issued Date: 2017.06.13
Revised Date: 2017.06.13

Document Ref. No:
SB-report-170613

Revision:
2.0

Pages:
12 / 19

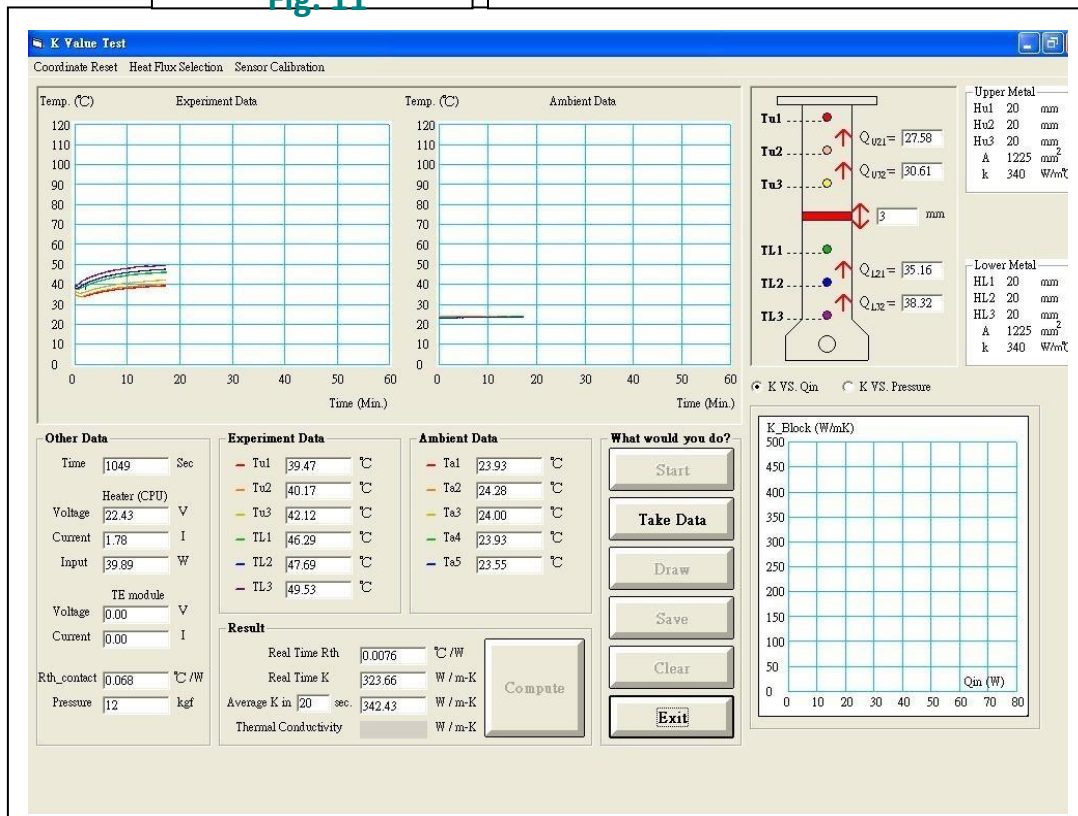
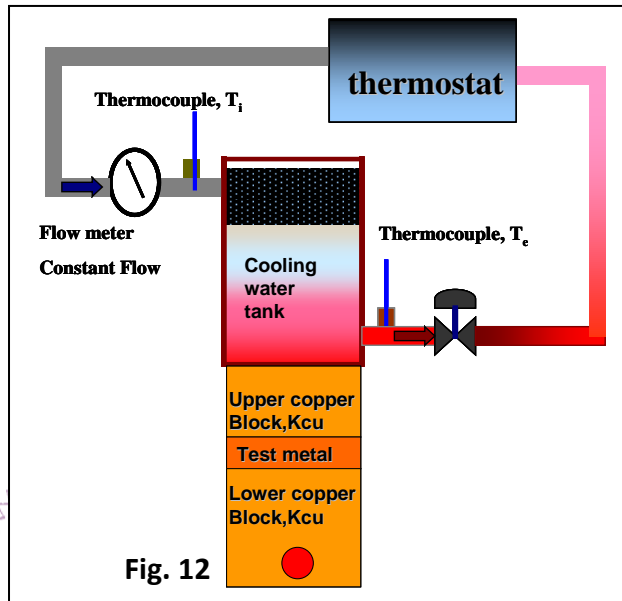
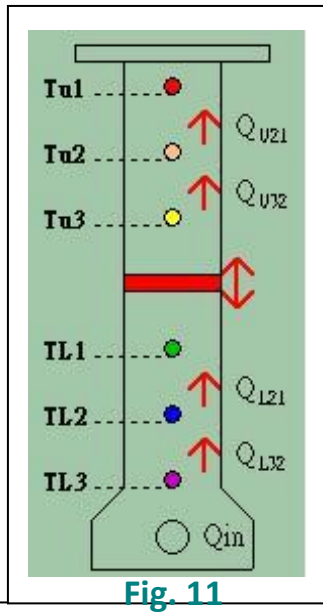

	National Tsing-Hua University--Taiwan ESS Dept.	TIM Performance Test	Advance Cooling Laboratory---ACL	
			Issued Date: 2017.06.13 Revised Date: 2017.06.13	Document Ref. No: SB-report-170613

Table 1. Sample test result for the thermal conductivity of the copper:

item	Qin(W)	Kcu (W/m, ⁰ C)	K _{Cu,reference}	Error (%)
No.1	19.90	387.52	390	0.64
No.2	31.11	400.17	390	2.61
No.3	39.85	378.27	390	3.01
Average		388.65		0.35

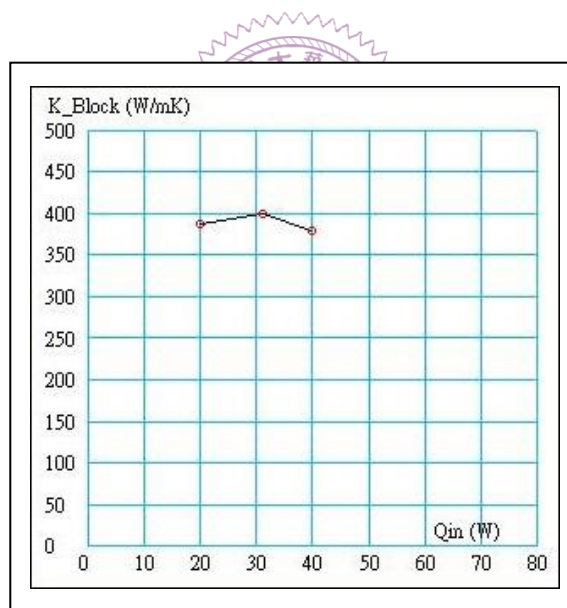



Fig.14 K value for Cu with respect to different Q

	National Tsing-Hua University--Taiwan ESS Dept.	TIM Performance Test		Advance Cooling Laboratory---ACL	
		Issued Date: 2017.06.13 Revised Date: 2017.06.13	Document Ref. No: SB-report-170613	Revision: 2.0	Pages: 14 / 19

2.2.3 K measurement for thermal grease

The same procedure as in the (2.2.2), put the different thickness of the Teflon spacer (Fig.15) between the lower module and upper module and fill with the thermal grease into the spacer then start to test. Fig. 16 shows the thermal resistance of the grease Vs. the thickness, the slop of the extrapolation line represents the $(1/K_{gr}A)$. The contact thermal resistance between the lower copper block and the upper copper block, $R_{contact}$, is the thermal resistance when the thickness of the grease H_s approach to "0". Table 2 is the sample test result for the K value of thermal grease. Fig. 17 is the Monitor menu for K value of the grease, Fig.18 is the data inquire for the K value of the grease

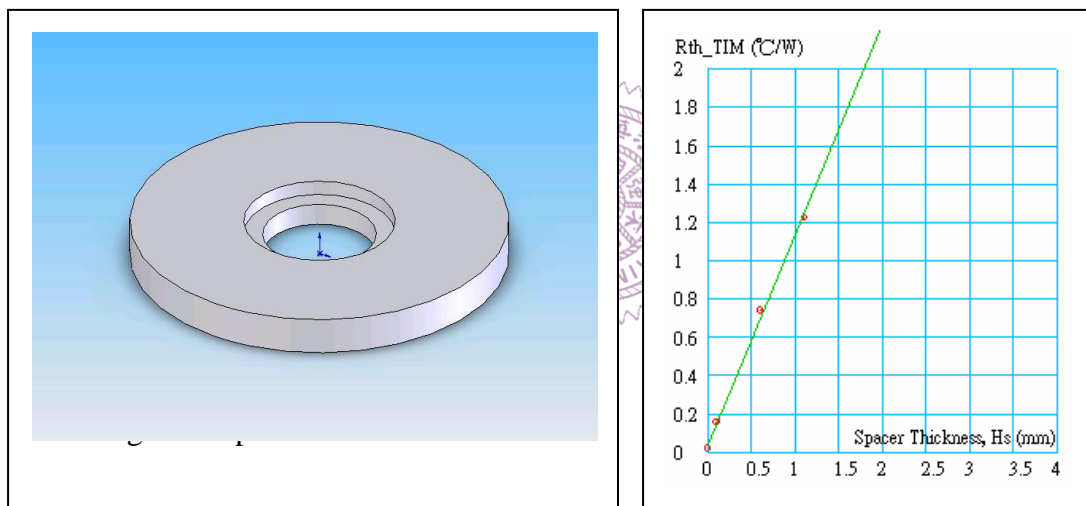

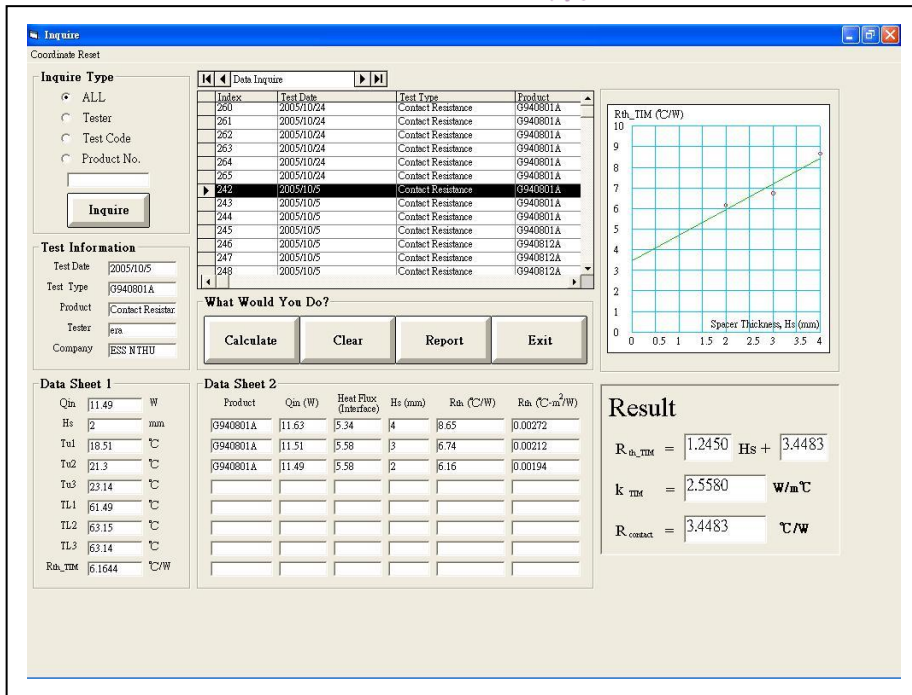
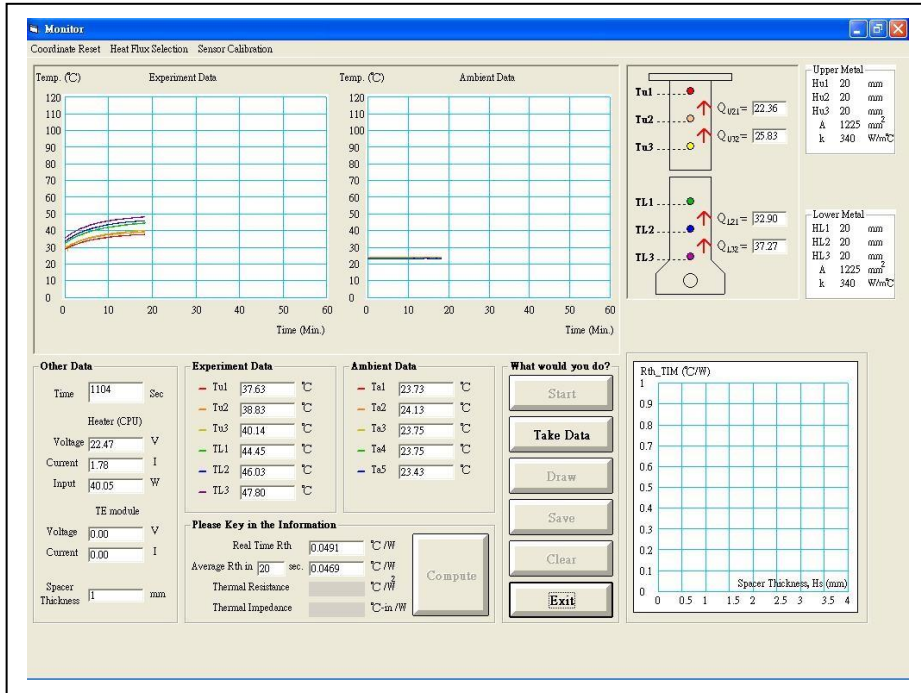



Fig. 16 Rth Vs. spacer thickness

Table 2. Sample test result for the K value of thermal grease:

item	$Q_{in}(W)$	$H_s(mm)$	$R_{th}(^{\circ}C/W)$
No.1	20.05	1.1	1.2270
No.2	20.13	0.6	0.7443
No.3	20.08	0.1	0.1597
No.4	20.17	0	0.0237
$R_{th_TIM} = 1.1081 * H_s + 0.0340$			
$K_{TIM} = 0.7367 W/m^{\circ}C$			
$R_{contact} = 0.0350 ^{\circ}C/W$			

	National Tsing-Hua University--Taiwan ESS Dept.	TIM Performance Test	Advance Cooling Laboratory---ACL	
			Issued Date: 2017.06.13 Revised Date: 2017.06.13	Document Ref. No: SB-report-170613



	National Tsing-Hua University--Taiwan ESS Dept.	TIM Performance Test	Advance Cooling Laboratory---ACL	
			Issued Date: 2017.06.13 Revised Date: 2017.06.13	Document Ref. No: SB-report-170613

2.2.4 K measurement for thermal pad

The same procedure as in the (2.2.3), put the thermal pad between the lower module and upper module. Clamp these two modules together with different amount of pressure and then start to test. Fig. 19 shows the thermal resistance of the pad Vs. the pressure. Fig.20 is the data inquire for the K value of the pad

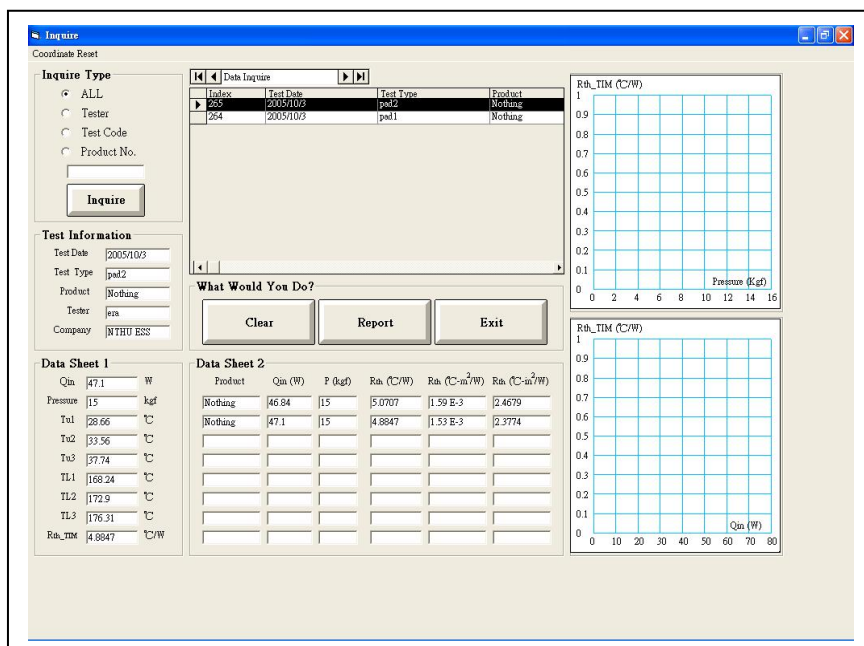
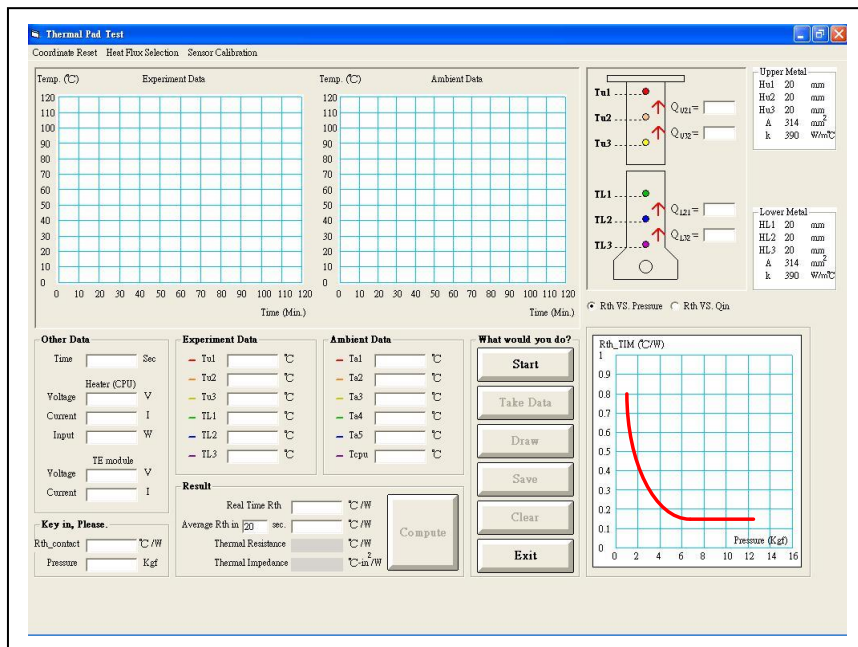

	National Tsing-Hua University--Taiwan ESS Dept.	TIM Performance Test	Advance Cooling Laboratory---ACL	
Issued Date: 2017.06.13 Revised Date: 2017.06.13		Document Ref. No: SB-report-170613	Revision: 2.0	Pages: 17 / 19

2.3 Test Results

2.3.1 Thermal grease

2.3.1.1-Sample1----see attached file Sample1_G79-SiC-A

2.3.1.2-Sample2----see attached file Sample2_G79-SiC-B



	National Tsing-Hua University--Taiwan ESS Dept.	TIM Performance Test	Advance Cooling Laboratory---ACL	
			Issued Date: 2017.06.13 Revised Date: 2017.06.13	Document Ref. No: SB-report-170613

TIM Performance Test Report

Product No. : Sample 1_G79-SiC-A

Company : NTHU

Tester : E, YA LING

Test Date : 2017/05/02

K : 3.0455 (W/m°C)

Thermal Resistance vs. Pressure

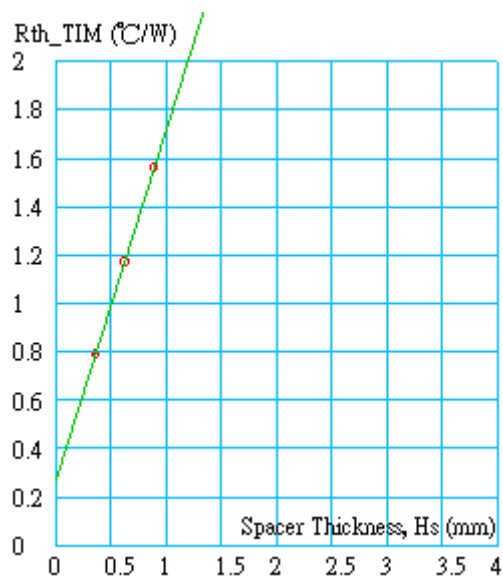

	Qin (W)	Hs (mm)	Tu1 (°C)	Tu2 (°C)	Tu3 (°C)	TL1 (°C)	TL2 (°C)	TL3 (°C)	R _{th} (°C/W)
No.1 :	20.02	0.358	35.90	38.00	41.30	62.70	66.00	68.50	0.7938
No.2 :	20.05	0.628	35.00	37.10	40.20	68.80	71.90	74.40	1.1751
No.3 :	20.00	0.890	31.20	33.30	36.10	71.80	75.00	77.50	1.5620

	National Tsing-Hua University--Taiwan ESS Dept.	TIM Performance Test		Advance Cooling Laboratory---ACL	
		Issued Date: 2017.06.13 Revised Date: 2017.06.13	Document Ref. No: SB-report-170613	Revision: 2.0	Pages: 19 / 19

TIM Performance Test Report

Product No. : SG-Sample 2_G79-SiC-B

Company : NTHU

Tester : E, YA LING

Test Date : 2017/05/16

K : 3.2575 (W/m°C)

Thermal Resistance vs. Pressure

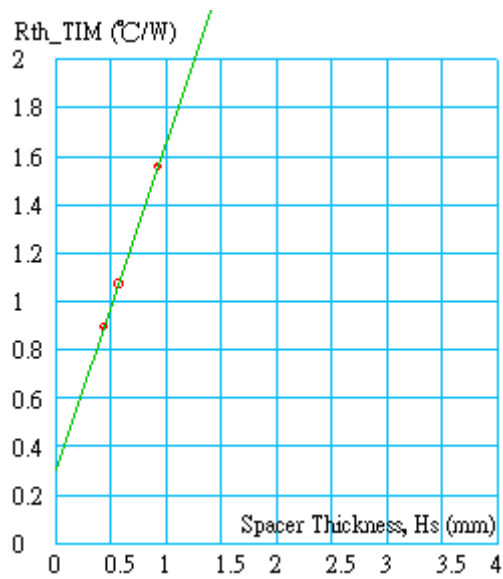

	Qin (W)	Hs (mm)	Tu1 (°C)	Tu2 (°C)	Tu3 (°C)	TL1 (°C)	TL2 (°C)	TL3 (°C)	R _{th} (°C/W)
No.1 :	20.04	0.430	36.70	38.70	42.00	65.10	68.20	70.70	0.8957
No.2 :	20.02	0.573	36.20	38.10	41.20	67.30	70.30	72.70	1.0736
No.3 :	19.93	0.922	36.90	38.80	41.80	77.20	80.20	82.70	1.5598