

DCF

20080



Ø200x80mm(Ø7.86"x3.14")



MOTOR	Outer rotor motor Ø92mm
IMPELLER	Plastic Impeller, Metal Plate
BEARING	Ball
OPERATING TEMPERATURE	-20°C to + 60°C
INSULATION RESISTANCE	10M Ω min. @500 VDC
DIELECTRIC STRENGTH	5mA Max. at 500 VAC for 1 minute
WEIGHT	1.86 Kg
ROHS COMPLIANCE	Yes
IP LEVEL	IP21 (Special IP Rating On Request)

200

mm

SPECIFICATION

MODEL NO.	RATED VOLTAGE(V)	RATED CURRENT(A)	INPUT POWER(W)	SPEED (RPM)	MAX. AIR PRESSURE		MAX. AIR FLOW		NOISE dB(A) @1M
					inchH2O	mmH2O	CFM	m3/min	
DCF20080V24SH	24	10.4	249.6	4300	4.18	106.28	550.7	15.58	80
DCF20080V28SH	28	8.6	240.8	4300	4.18	106.28	550.7	15.58	80
DCF20080V48SH	48	5.2	249.6	4300	4.18	106.28	550.7	15.58	80

DIMENSION

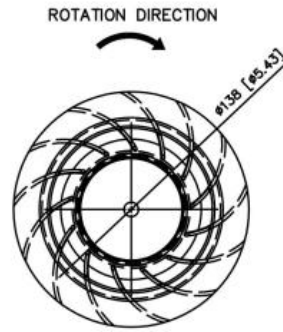
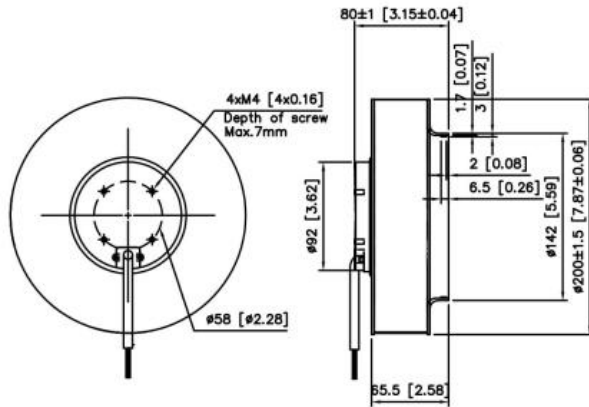

UNIT: mm[inch]

Wiring Diagram

Red — +VDC
 Blue — GND
 Yellow — 0-10V/PWM Speed Control
 White — Tachometer (FG)

AIR PERFORMANCE

